

TMEiC

We drive industry



TM-AC

Series 800 Frame Sizes

Replacing DC Auxiliary Motors
with the Latest in AC Motor Technology

Upgrade to the Latest Technology.

TMEIC's new TM-AC line of green, energy-saving motors are designed to mount directly to existing systems used for standard DC motors. They also match DC motor electrical characteristics and performances.

Characteristics



Compatibility with existing 800 Frame DC motors

- The newest induction motor is based on JEC-2137/IEC 60034-1 standards, maintaining compatibility with mechanical dimensions and electrical performance of DC motors.



Contributes to energy saving and CO₂ reduction due to improved operating efficiency

- Using the most appropriate structural and electrical designs, TMEIC has achieved significant improvement in efficiency compared with existing DC motors.

Frame Sizes	Direct Current Auxiliary Rolling Mill Motor Specifications			TM-AC Specifications	
	kW	rpm	Efficiency	Efficiency	Efficiency Improvement
806	22	650	87.6%	91.1%	3.5%
808	37	575	88.3%	92.5%	4.2%
810	52	550	88.6%	92.8%	4.2%
812	75	515	89.1%	93.5%	4.4%
814	110	500	90.4%	94.2%	3.8%
816	150	480	91.3%	94.8%	3.5%
818	185	435	91.8%	95.0%	3.2%



Robust Structure

- Using the latest technology for analysis and testing, TMEIC has improved the mechanical strength compared with the motors for general industries.



Easy Bearing Maintenance

- TMEIC has made improvements in our conventional bearing designs, which already had a reputation for long service life. As a result of these improvements, the greasing interval is twice as long as conventional bearings. TMEIC has achieved the longest lubrication interval of any supplier.
- Highly water-resistant bearings are used due to the extremely harsh operating environment.



Bearing Details

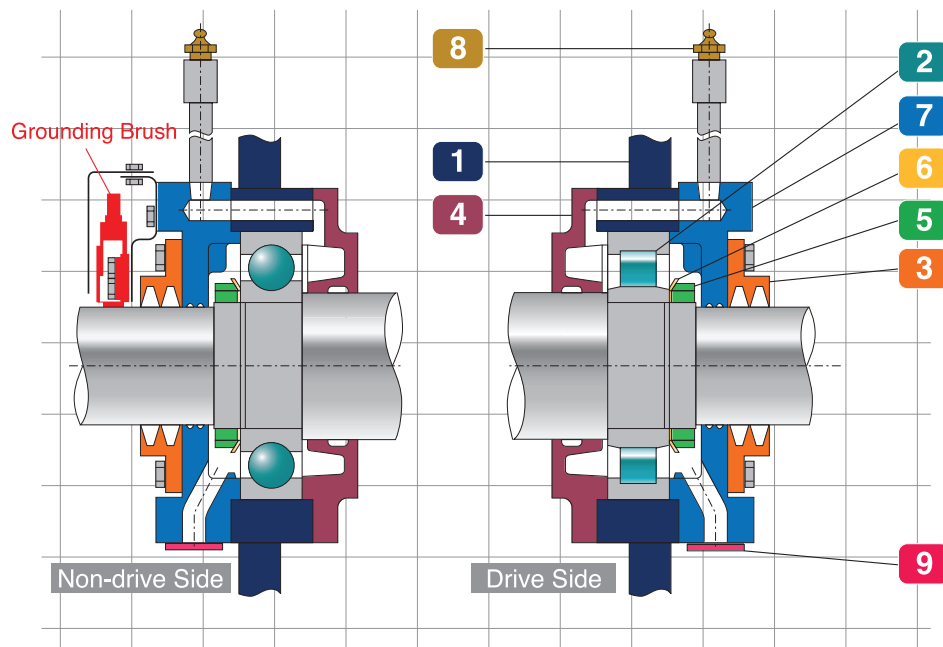

➤ As an option, a more water resistant labyrinth bearing structure can be applied.

Part No.

- | | |
|--|------------------------------|
| 1 Bracket | 6 Bearing Washer |
| 2 Roller (antifriction) Bearing | 7 Outer Bearing Cover |
| 3 Standard Seal | 8 Grease Inlet |
| 4 Inner Bearing Cover | 9 Grease Outlet |
| 5 Bearing Nut | |

Stator and Rotor

A form wound coil is used for the stator winding for excellent durability and long service life.



Stator (#816)



Rotor (#816)

Standard Rating List

TMEIC offers products with three speed ratings to match existing DC motor ratings. (Full, half and quarter speed designs)

Frame Size	Standard Speed		Half Speed		Low Speed (Quarter Speed)	
	Rated Output (kW)	Rotational Speed (rpm)	Rated Output (kW)	Rotational Speed (rpm)	Rated Output (kW)	Rotational Speed (rpm)
806	44	1300	22	650	11	325
808	74	1150	37	575	14.8	287
810	104	1100	52	550	20.8	275
812	150	1030	75	515	30	216
814	220	1000	110	500	44	200
816	300	960	150	480	60	192
818	370	870	185	435	74	174

Note: *Half speed is the standard speed rating for existing DC motors.
 *Standard speed is the rated speed for double-voltage applications.

Specifications

Basic Specifications	Standard	Standard based on JEC-2137/IEC 60034-1
	Type	Totally Enclosed Force-Ventilated (TEFV/IP44) Drip Proof Force-Ventilated (DPFV/IP24S) Totally Enclosed Non-Ventilated (TENV/IP44)
	Frame Size	All 7 frame sizes (806, 808, 810, 812, 814, 816, 818)
	Insulation	Insulation classifications: Thermal classification 155 (Class F) Temperature rise: 105 k (by resistance method)
	Standard Accessories	Grounding Brush, Terminal Box
	Optional Accessories	RTD, Speed Sensor, Brake, Shaft Cover

Electrical Characteristics	Rating	TENV – 1 hour Rating, TEFV – Continuous Rating
	Voltage	Standard Maximum Voltage: 420 Vac max. (Low speed type; Multiple motor drive: 400 Vac max.)
		Maximum Inverter DC bus voltage: 680 Vdc
Maximum Torque	Maximum Torque at base speed and rated voltage: 300% or higher	

Mechanical Specifications	Structure	Frame is made of Steel plate, Non-split type
	Shaft/end of shaft	Two shaft extensions type, the end of shaft: Sealed Structure (corresponds to IP55), labyrinth structure is optional.
	Vibration Rating	3G
	Terminal Box	Fr 806-812: Frame Top (changeable as an option) Fr 814-818: Frame Side (changeable as an option)
	Coupling	Cylindrical shaft with key

Drawings

806

808

810

812

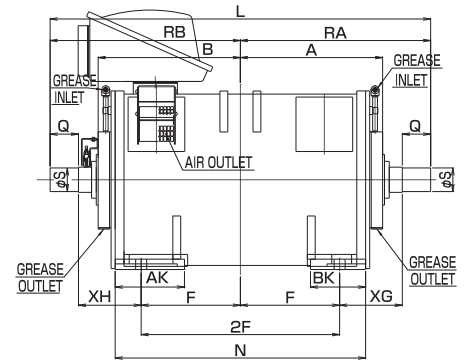
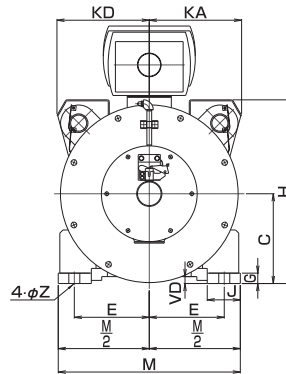

Frame size	A	B	C	KA	KD	E	F	G	H	J	AK	BK	L	M	N	RA	RB	Z	S
806	410	410	254	273	273	210	265	27	532	95	200	170	1074	508	698	537	537	28	65
808	454	454	285	293	293	238	315	33	583	105	220	175	1208	578	795	604	604	35	75
810	475	475	311	321	321	260	330	33	671	110	225	185	1276	622	825	638	638	35	85
812	520	520	339	362	362	285	362	33	730	115	255	195	1396	685	915	698	698	35	95

Frame size	A	B	C	KA	KD	E	F	G	H	J	AK	BK	L	M	N	RA	RB	Z	S
806	16.14	16.14	10.00	10.75	10.75	8.27	10.43	1.06	29.92	3.74	7.87	6.69	42.28	20.00	27.48	21.14	21.14	1.10	φ2.56p6
808	17.87	17.87	11.22	11.54	11.54	9.37	12.40	1.30	32.20	4.13	8.66	6.89	47.56	22.76	31.30	23.78	23.78	1.38	φ2.95p6
810	18.70	18.70	12.24	12.64	12.64	10.24	12.99	1.30	34.96	4.33	8.86	7.28	50.24	24.49	32.48	25.12	25.12	1.38	φ3.35p6
812	20.47	20.47	13.35	14.25	14.25	11.22	14.25	1.30	37.24	4.53	10.04	7.68	54.96	26.97	36.02	27.48	27.48	1.38	φ3.74p6

814

816

818

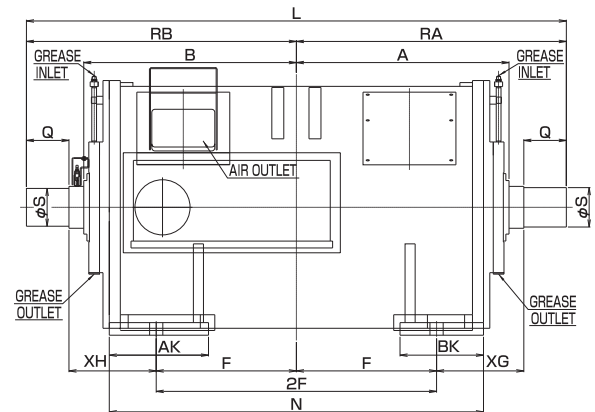
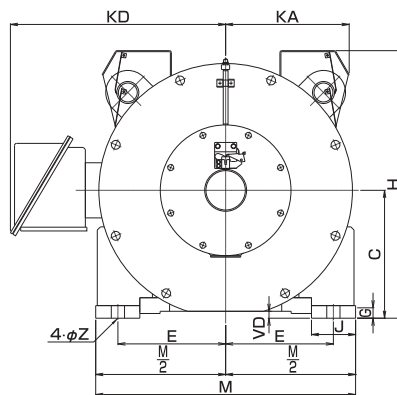

Frame size	A	B	C	KA	KD	E	F	G	H	J	AK	BK	L	M	N	RA	RB	Z	S
814	589	589	374	361	361	318	405	40	781	130	270	235	1542	762	1055	771	771	42	110
816	660	660	406	392	683	342	445	40	849	140	315	270	1714	825	1188	857	857	42	120
818	698	698	450	441	723	380	495	45	925	155	335	265	1792	915	1265	896	896	47	130

Frame size	A	B	C	KA	KD	E	F	G	H	J	AK	BK	L	M	N	RA	RB	Z	S
814	23.19	23.19	14.72	14.21	25.55	12.52	15.94	1.57	30.75	5.12	10.63	9.06	60.71	30.00	41.54	30.35	30.35	1.65	φ4.33p6
816	25.98	25.98	15.98	15.43	28.54	13.46	17.52	1.57	33.43	5.51	12.40	10.63	67.48	32.48	46.77	33.74	33.74	1.65	φ4.72p6
818	27.48	27.48	17.72	17.36	30.16	14.96	19.49	1.77	36.42	6.10	13.19	10.43	70.55	36.02	49.80	35.28	35.28	1.85	φ5.12p6

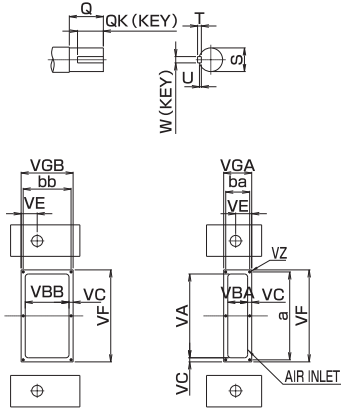

(unit: mm)

Q	QK	W	U	T	XG	XH	VA	VBA	VBB	VC	VD	VE	VF	VGA	VGB	a	ba	bb	VZ
80	65	18	7	11	192	192	234	60	126	13	13	54	260	86	152	247	73	139	4-M6
90	75	20	7.5	12	199	199	266	63	139	13	22	51	292	89	165	279	76	152	6-M6
100	80	22	9	14	208	208	279	66	152	13	22	54	305	92	178	292	79	165	6-M6
112	92	25	9	14	224	224	317	92	178	16	22	64	349	124	210	333	108	194	6-M6

(unit: inch)

Q	QK	W	U	T	XG	XH	VA	VBA	VBB	VC	VD	VE	VF	VGA	VGB	a	ba	bb	VZ
3.15	2.56	0.71	0.28	0.43	7.56	7.56	9.21	2.36	4.96	0.51	0.51	2.13	10.24	3.39	5.98	9.72	2.87	5.47	4-M6
3.54	2.95	0.79	0.30	0.47	7.83	7.83	10.47	2.48	5.47	0.51	0.87	2.01	11.50	3.50	6.50	10.98	2.99	5.98	6-M6
3.94	3.15	0.87	0.35	0.55	8.19	8.19	10.98	2.60	5.98	0.51	0.87	2.13	12.01	3.62	7.01	11.50	3.11	6.50	6-M6
4.41	3.62	0.98	0.35	0.55	8.82	8.82	12.48	3.62	7.01	0.63	0.87	2.52	13.74	4.88	8.27	13.11	4.25	7.64	6-M6

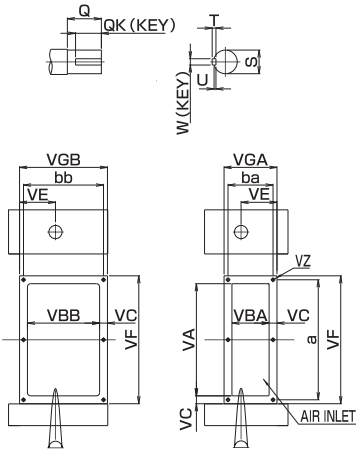

(unit: mm)

Q	QK	W	U	T	XG	XH	VA	VBA	VBB	VC	VD	VE	VF	VGA	VGB	a	ba	bb	VZ
125	105	28	10	16	241	241	355	108	203	16	22	86	387	140	235	371	124	219	6-M6
140	115	32	11	18	272	272	356	118	229	25	22	114	406	168	279	381	143	254	6-M10
140	115	32	11	18	261	261	407	131	255	25	22	98	457	181	305	432	156	280	6-M10

(unit: inch)

Q	QK	W	U	T	XG	XH	VA	VBA	VBB	VC	VD	VE	VF	VGA	VGB	a	ba	bb	VZ
4.92	4.13	1.10	0.39	0.63	9.49	9.49	13.98	4.25	7.99	0.63	0.87	3.39	15.24	5.51	9.25	14.61	4.88	8.62	6-M6
5.51	4.53	1.26	0.43	0.71	10.71	10.71	14.02	4.65	9.02	0.98	0.87	4.49	15.98	6.61	10.98	15.00	5.63	10.00	M10
5.51	4.53	1.26	0.43	0.71	10.28	10.28	16.02	5.16	10.04	0.98	0.87	3.86	17.99	7.13	12.01	17.01	6.14	11.02	M10



TOSHIBA MITSUBISHI-ELECTRIC INDUSTRIAL SYSTEMS CORPORATION
Mita 43 MT Bldg., 13-16 Mita 3 chome, Minato-ku Tokyo, 108-0073 Japan
Tel.: +81-3-5444-3828, www.tmeic.co.jp

TMEIC Corporation

1325 Electric Road, Suite 200, Roanoke, VA, United States 24018
Tel.: +1-540-283-2000; info@tmeic.com, www.tmeic.com

TMEIC Corporation, Houston Branch

2901 Wilcrest Dr., Suite 110, Houston, TX 77042
Tel.: +1-713-784-2163, OilGas@tmeic.com, www.tmeic.com

TMEIC Europe Limited

6-9 The Square, Stockley Park, Uxbridge, Middlesex, UB11 1FW, United Kingdom
Tel.: +61-2-9788-6600, info@tmeic.eu, www.tmeic.com